

Katalog uchwyty: MIG - TIG - PLAZMA + cz ci eksploatacyjne



# Uchwyty MIG

MB 145



MB 14



# Uchwyty MIG

MB 15



MB 24



# Uchwyty MIG

## MB 25



## MB 36



# Uchwyty MIG

MB 401



MB 501

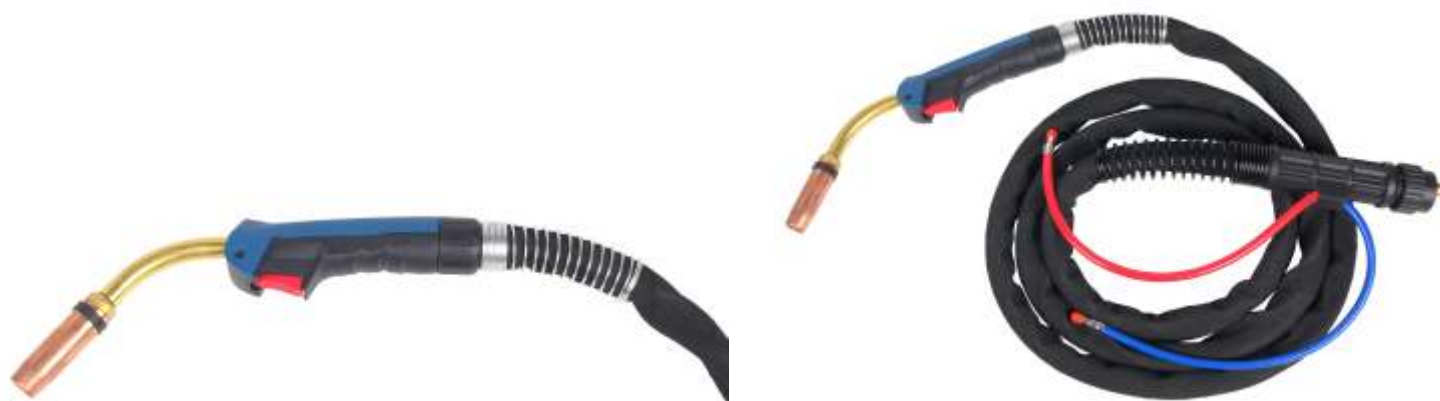

# Uchwyty TIG

SR 17



SR 17v



# Uchwyty TIG

SR 17 N

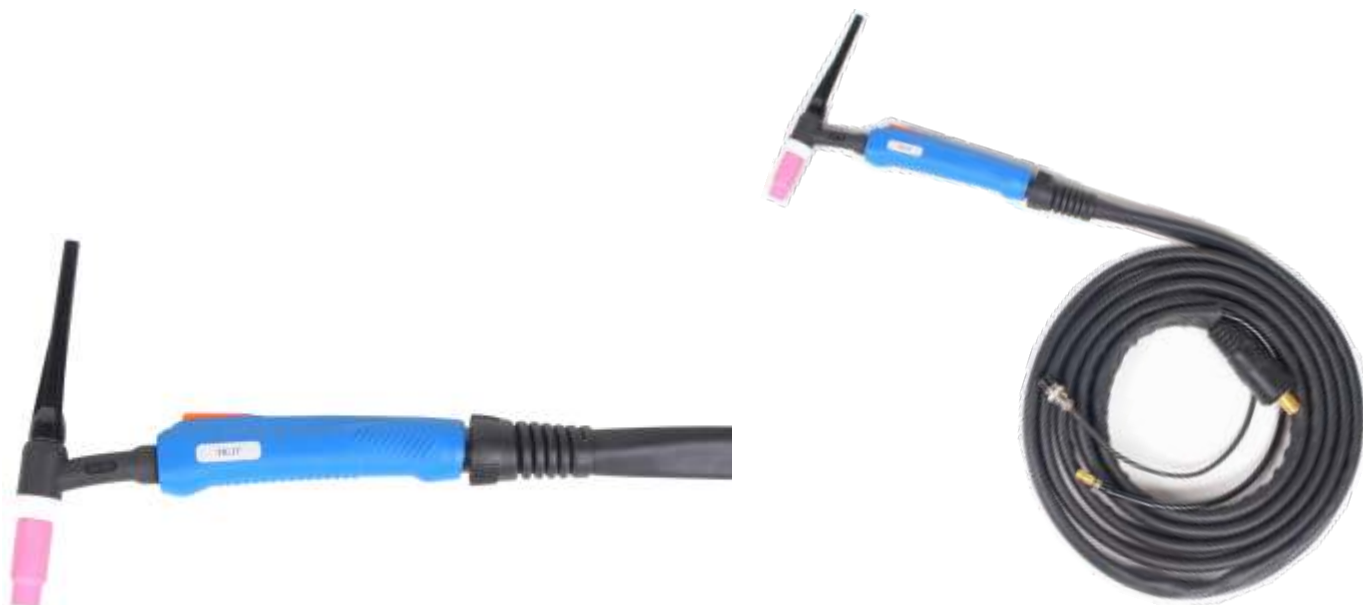

SR 18



# Uchwyty TIG

SR 20



SR 26



# Katalog uchyty TIG

## SR 26v



## SR 26 N



# Uchwyty PLAZMA

S 45



S 75



# Uchwyty PLAZMA

A-101



A-141



# Czesci eksploatacyjne uchwytów spawalniczych MIG-MAG



DYSZE GAZOWE



SGA 145 15 24 25 36 401

LACZNIKI



15 M-6 25 M-6 401/501 M-8  
 KO CÓWKI PR DOWE 15 AK 25 AK 401B 36KD 24KD  
 SPR YNY TULEJE IZOLACYJNE

# Człci eksploatacyjne uchwytów spawalniczych TIG

## SR 17-18-26



TUL WP26	∅ 1.6	10N23	
TUL WP26	∅ 2.0		
TUL WP26	∅ 2.4	10N24	
TUL WP26	∅ 3.2	10N25	
TUL WP26	∅ 4.0	54N20	

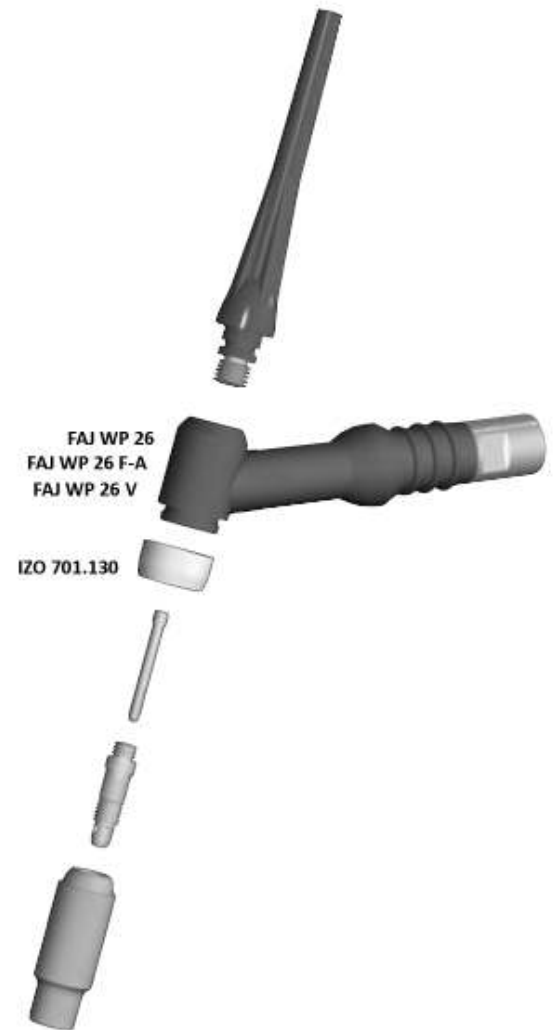

ŁĄCZ WP26	∅ 1.6	10N31
ŁĄCZ WP26	∅ 2.0	
ŁĄCZ WP26	∅ 2.4	10N32
ŁĄCZ WP26	∅ 3.0	
ŁĄCZ WP26	∅ 3.2	10N28
ŁĄCZ WP26	∅ 4.0	406488

SOC WP26	∅ 1.0	
SOC WP26	∅ 1.6	
SOC WP26	∅ 2.0	
SOC WP26	∅ 2.4	
SOC WP26	∅ 3.0	
SOC WP26	∅ 3.2	
SOC WP26	∅ 3.2	

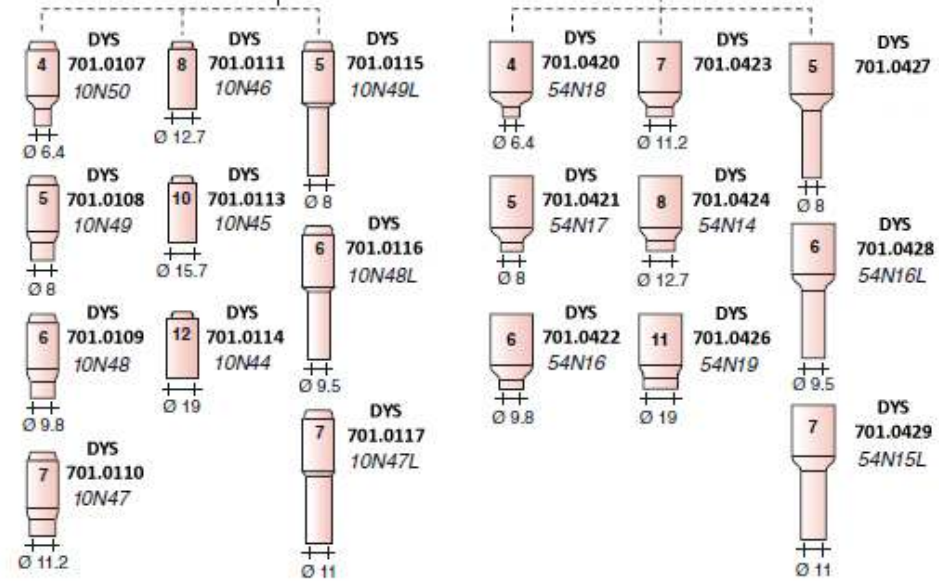

# Człci eksploatacyjne uchwytów spawalniczych TIG

## SR 9-20

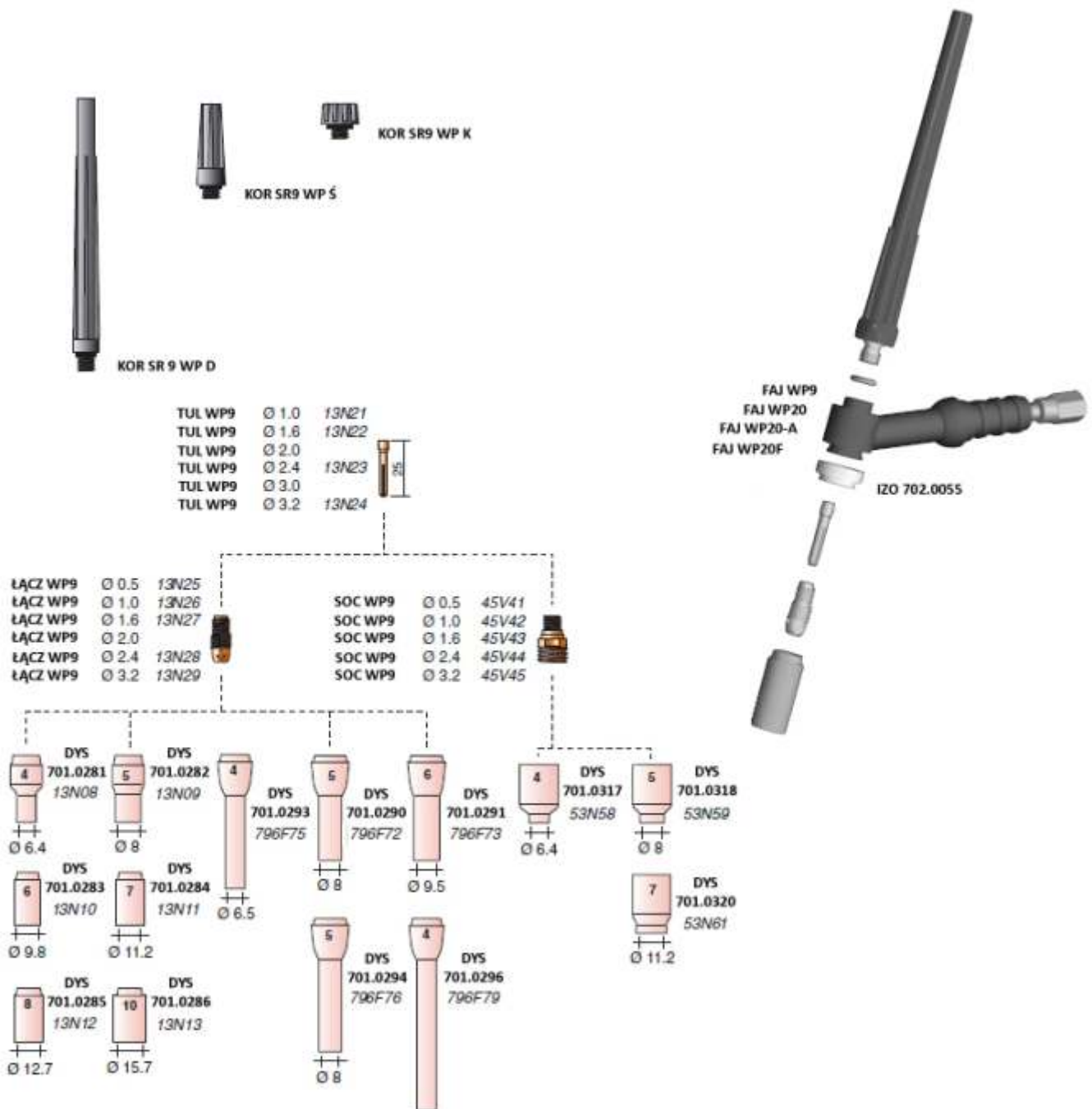

# Człci eksploatacyjne uchwytów palników PLAZMOWYCH

S 45

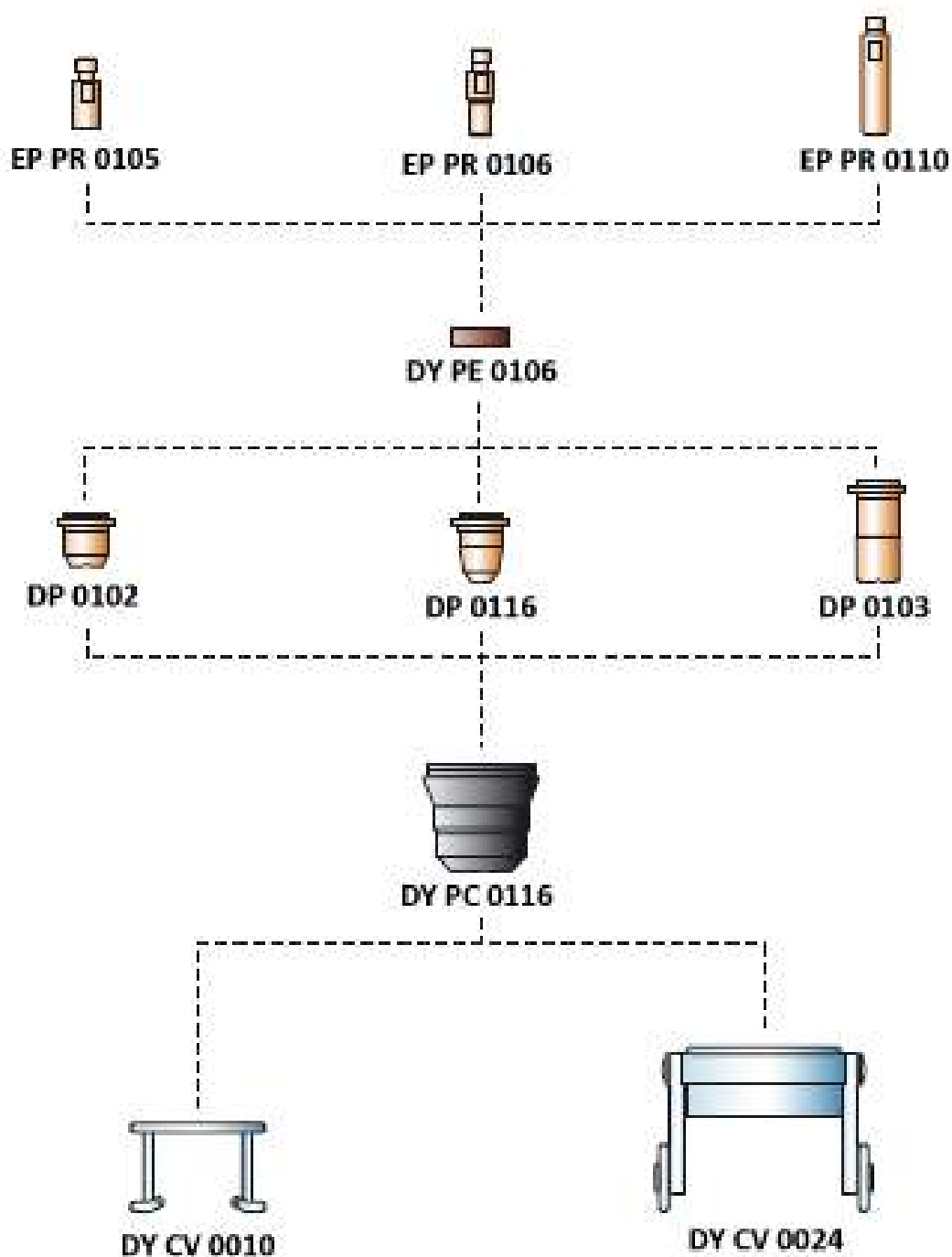

# Człci eksploatacyjne uchwytów palników plazmowych

## PLAZMOWYCH

S 75

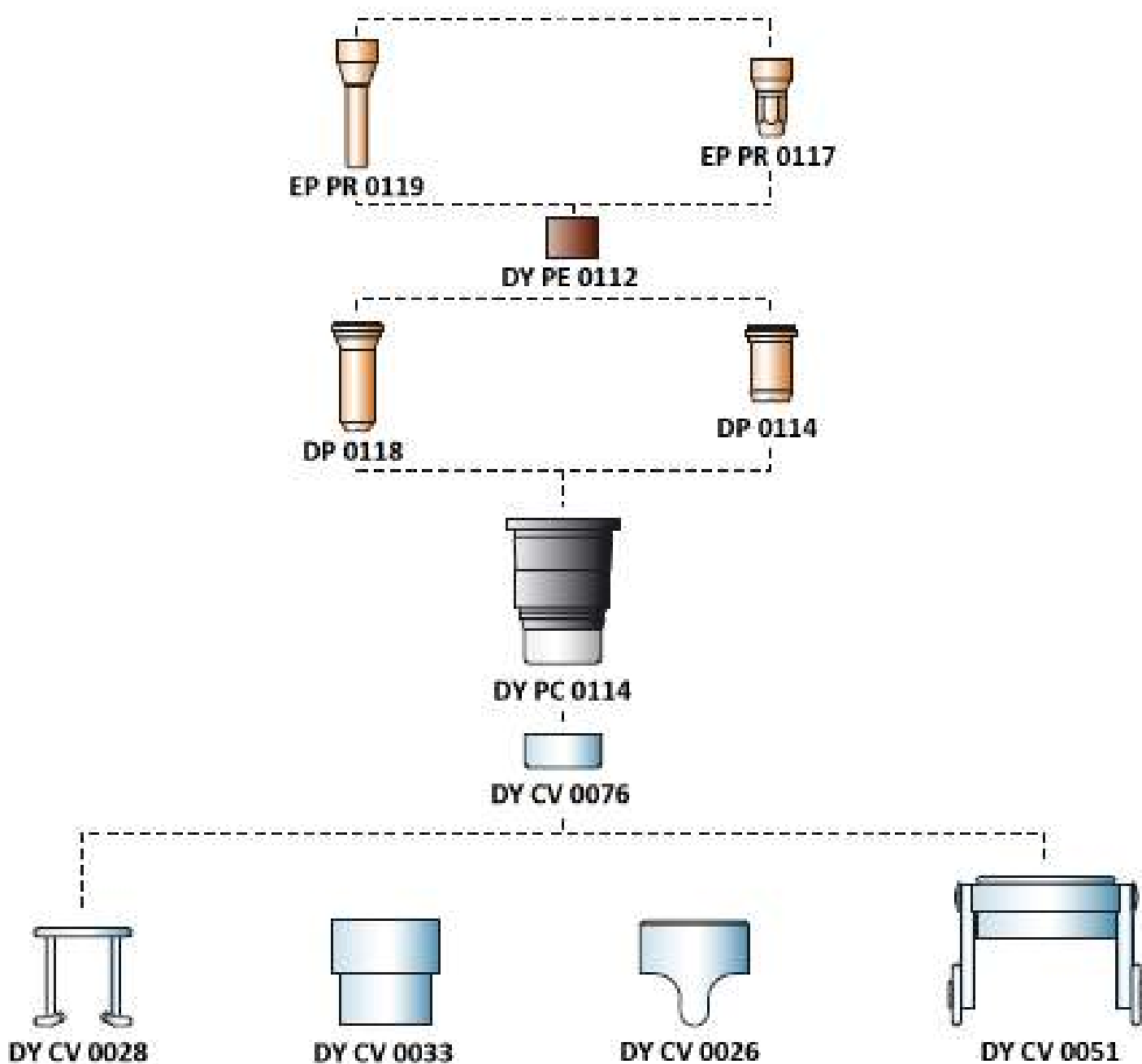

# Człci eksploatacyjne uchwytów palników plazmowych

## PLAZMOWYCH

### A-101

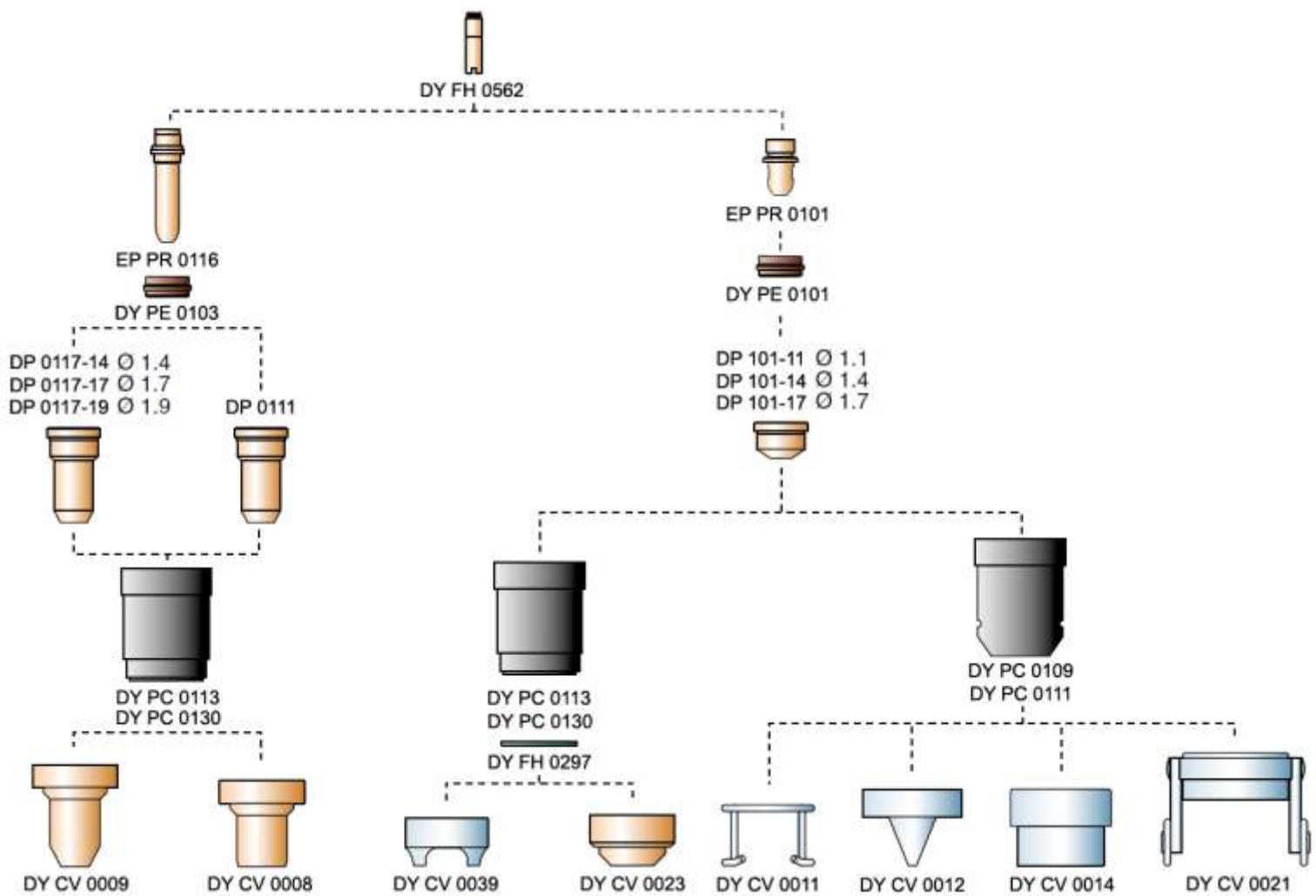

# Człci eksploatacyjne uchwytów palników plazmowych

## PLAZMOWYCH

A-141

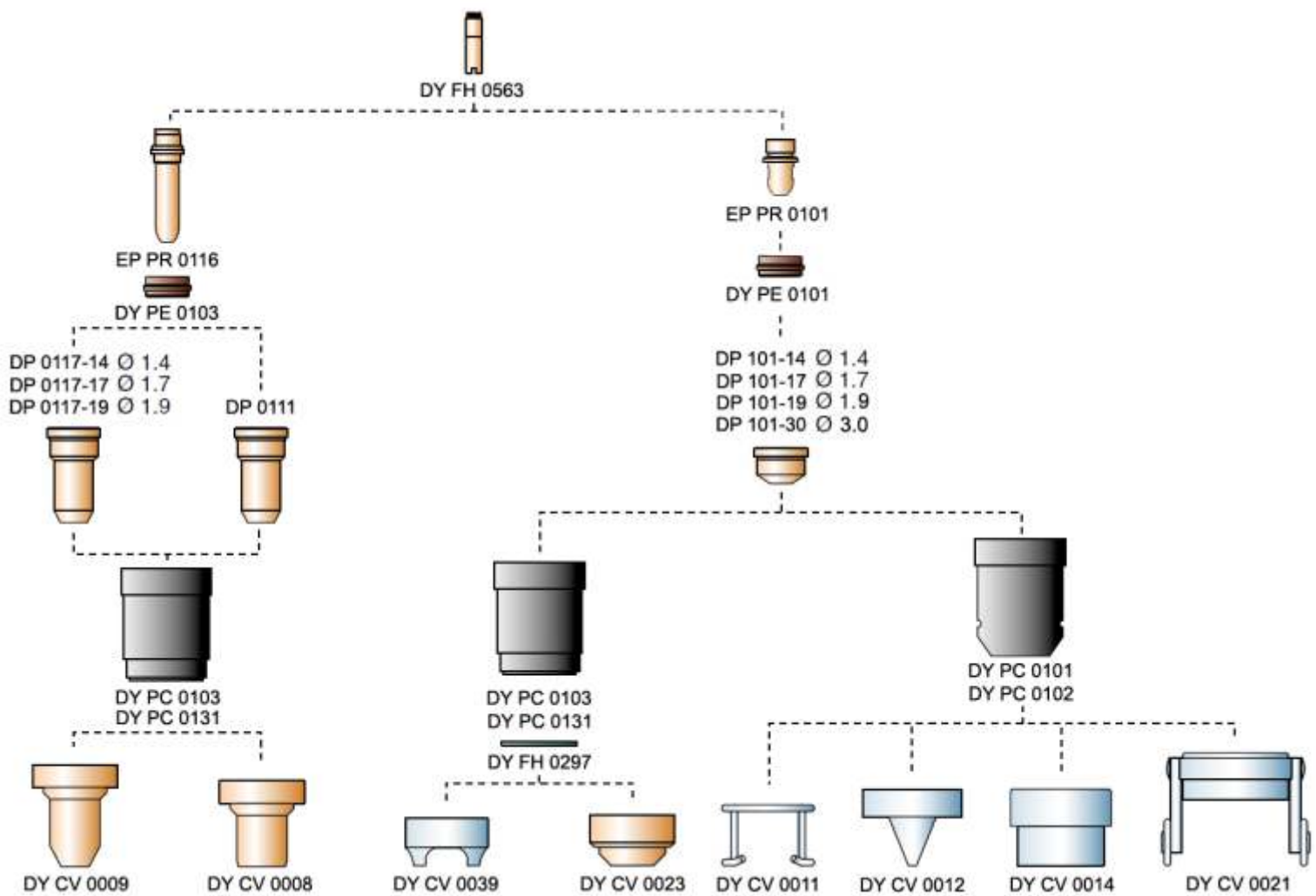

# Zachęcamy do zapoznania się z naszymi innymi katalogami:



**W celu uzyskania szczegółowych informacji prosimy o kontakt z naszym regionalnym przedstawicielem handlowym:**



## ***FIRMA SPAW***

**SPAWALNICTWO**  
**NARZĘDZIA**

ul. Grzegórzecka 79, 31-559 Kraków  
tel. 12 / 411-99-26  
fax. 12 / 412-98-92  
[grzegorzecka@spawsc.pl](mailto:grzegorzecka@spawsc.pl)

***PNEUMATYKA***

ul. Nowohucka 92 , 30-728 Kraków  
tel. 12 / 414-05-00  
fax. 12 / 414-05-00 (wew. 15)  
[technika@spawsc.pl](mailto:technika@spawsc.pl)

**[www.spawsc.pl](http://www.spawsc.pl)**